

Diagnoseadapter 02d

Für Mikrocontroller

3-stellig HEX. 12 Bits Eingabe (Schiebepinzipp), 12 Bits Zählweite

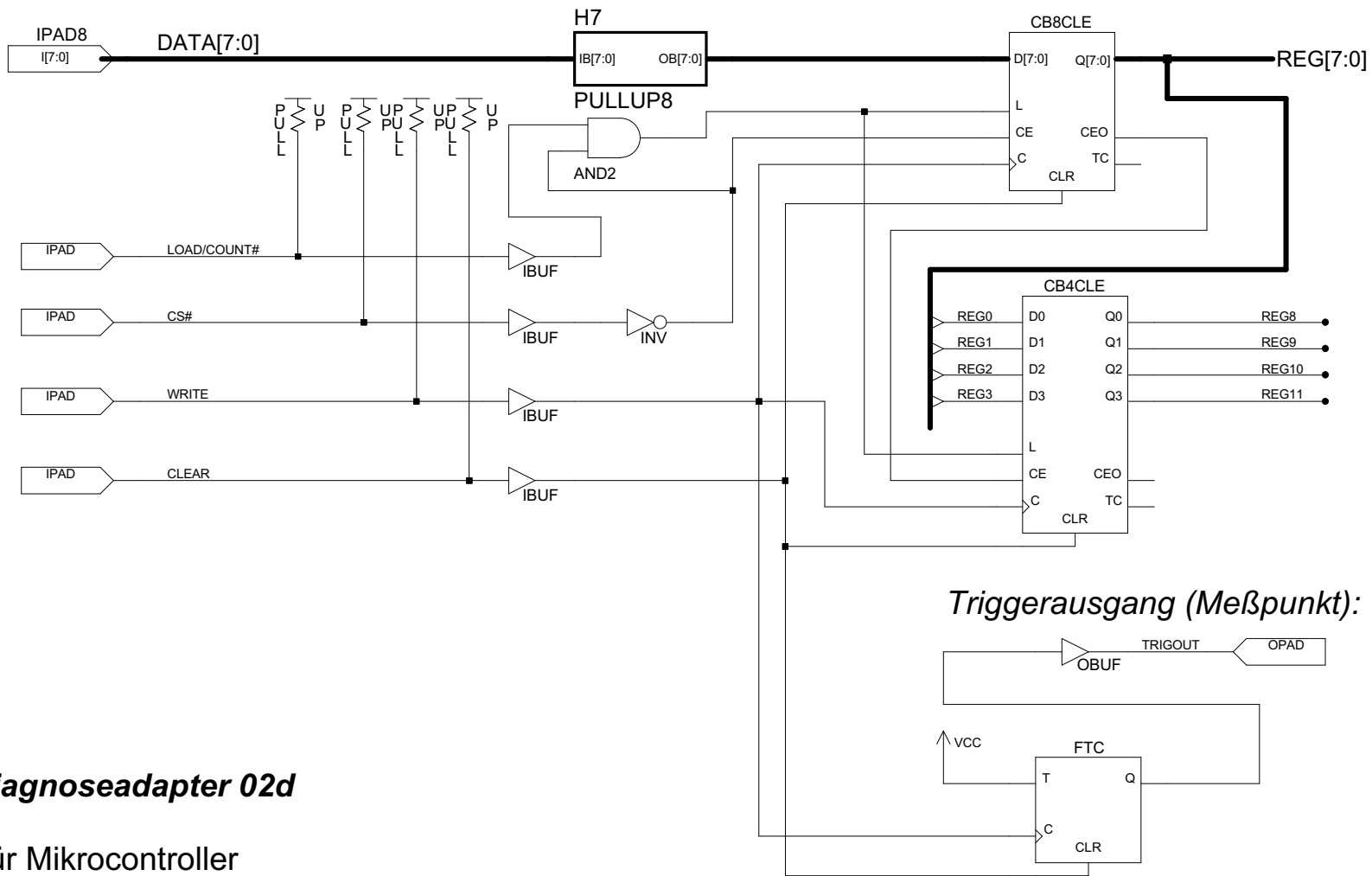

Diagnoseadapter 02d	Project: DIAD02D
f. Mikrocontr. (3stell.)	Sheet: 1/2
Dr. Matthes	Date: 01/07/03
Project: Diagnoseadapter 02d	

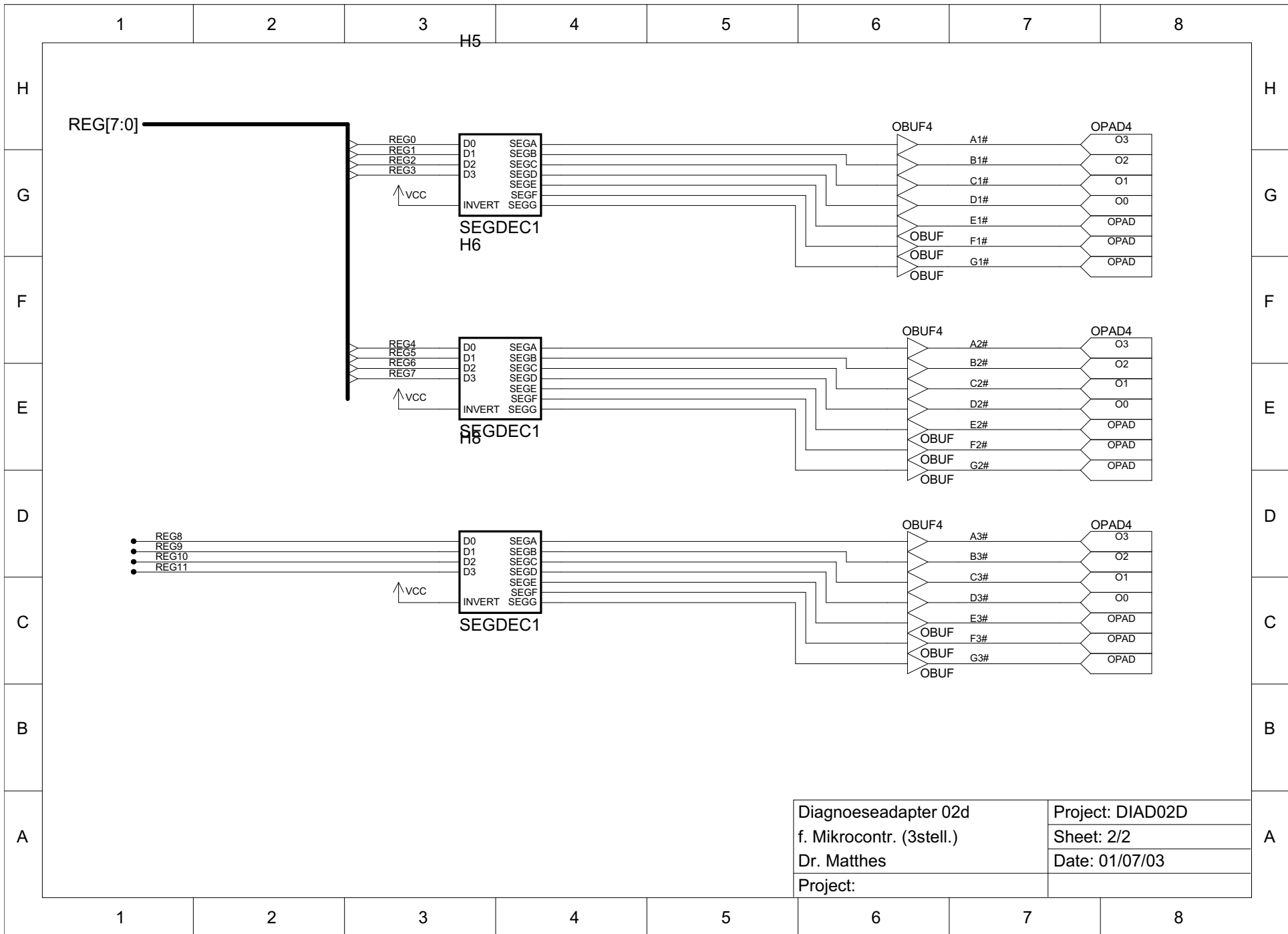

Diagnoesadapter 02d
 f. Mikrocontr. (3stell.)
 Dr. Matthes
 Project:

Project: DIAD02D
 Sheet: 2/2
 Date: 01/07/03

A