

1 2 3 4 5 6 7 8

H H

G G

F F

E E

D D

C C

B B

A A

1 2 3 4 5 6 7 8

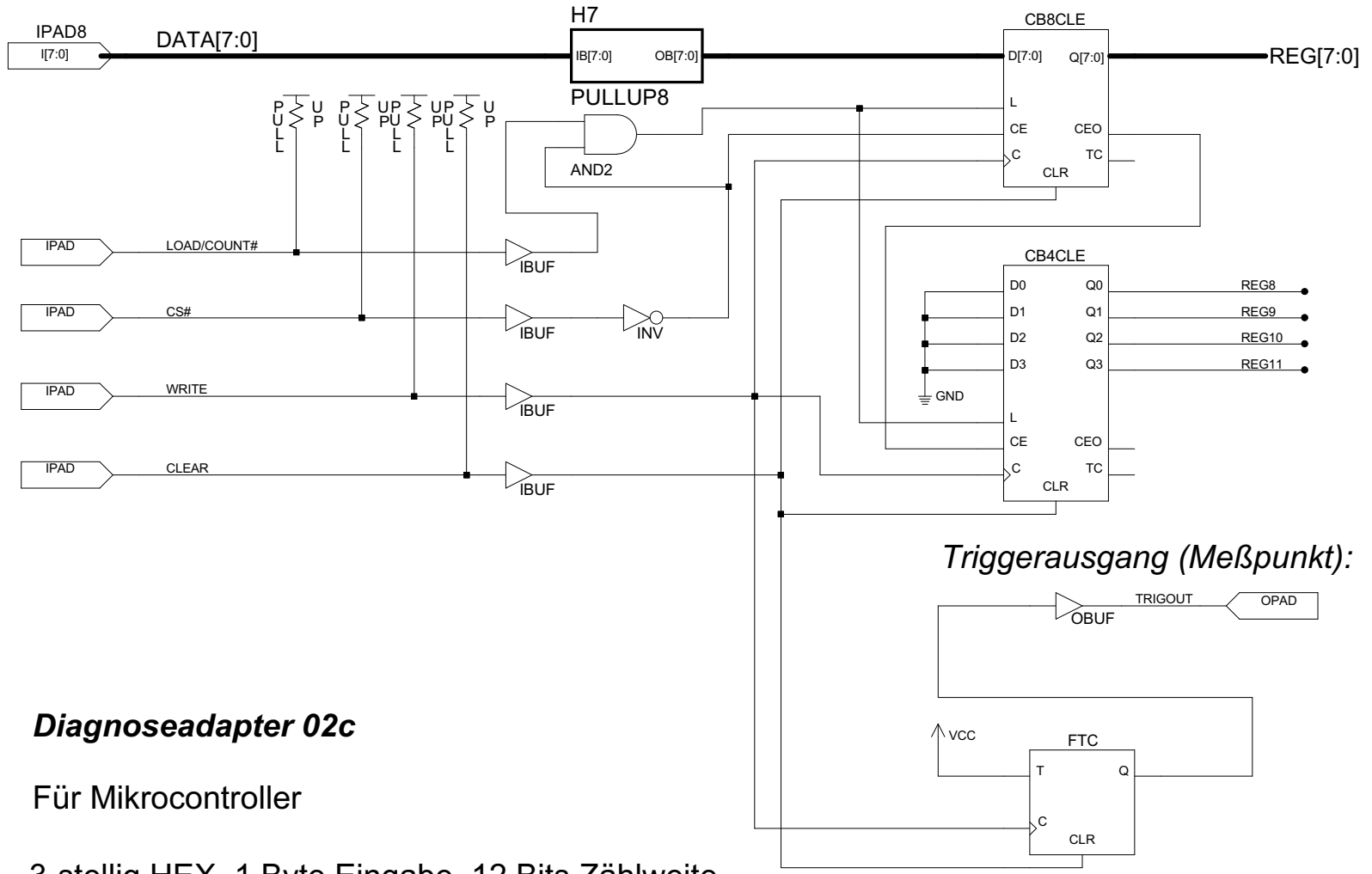

Diagnoseadapter 02c

Für Mikrocontroller

3-stellig HEX. 1 Byte Eingabe, 12 Bits Zählweite

Diagnoseadapter 02c	Project: DIAD02C
f. Mikrocontr. 8 Bits Eingabe, 3stell.	Sheet: 1/2
Dr. Matthes	Date: 01/07/03
Project: Diagnoseadapter 02c	

H

G

F

E

D

C

B

A

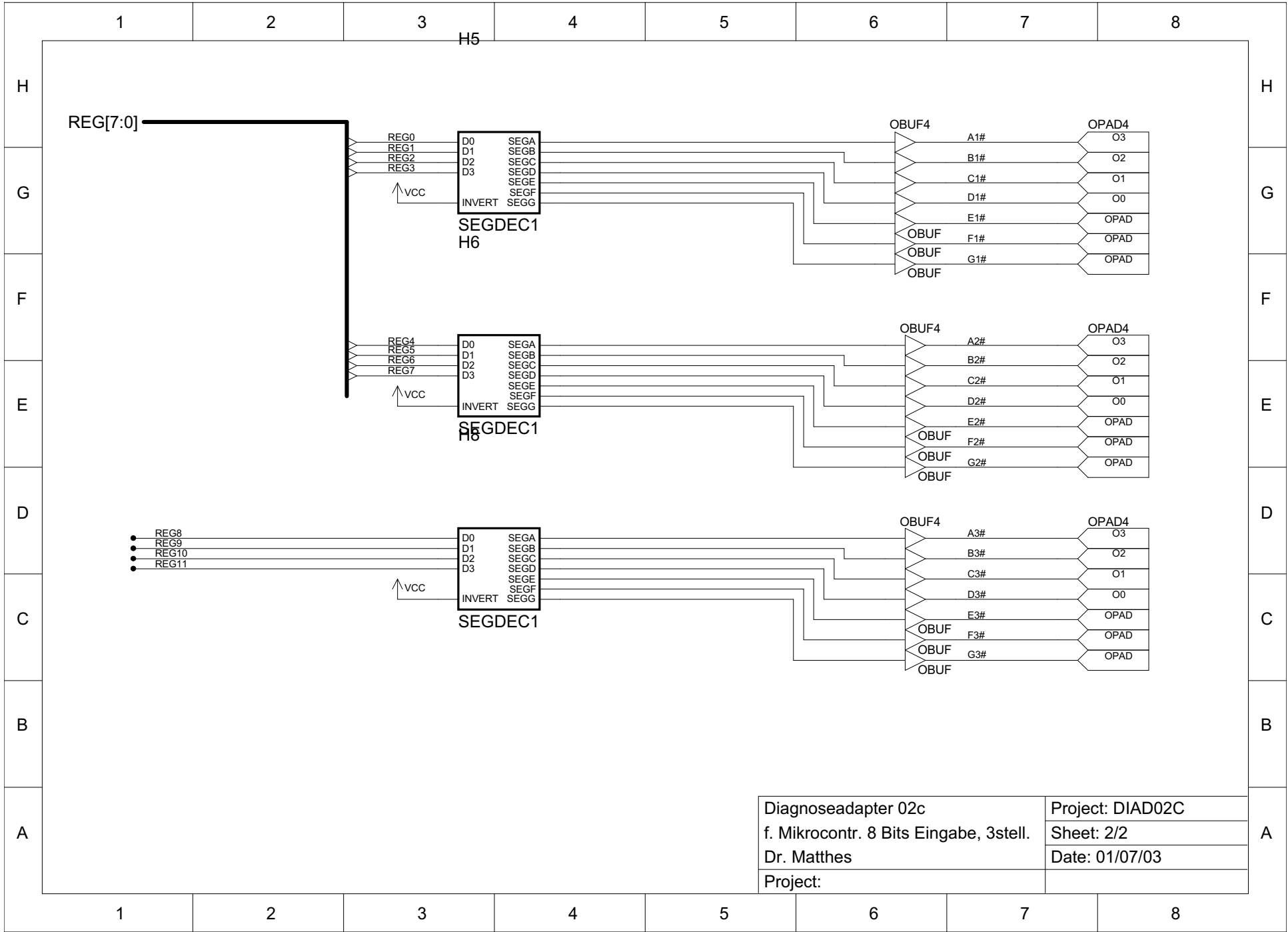

Diagnoseadapter 02c
 f. Mikrocontr. 8 Bits Eingabe, 3stell.
 Dr. Matthes
 Project:

Project: DIAD02C
 Sheet: 2/2
 Date: 01/07/03

A